

LADDER TRANSPORTER - LAD-MM-LTO

APPROX WEIGHT: 18.02 lbs.
 DOES NOT INCLUDE WEIGHT OF POWER OR PACKAGING!!!

*** ANY ADDITIONS, DELETIONS, OR OMISSIONS MUST BE CORRECTED ON THIS DRAWING AS THIS DRAWING WILL BE CONSIDERED ALL INCLUSIVE ***

ALL GRAPHICS PROVIDED ARE FOR REFERENCE ONLY. IF CERTAIN DIMENSIONS ARE CRITICAL PLEASE VERIFY THOSE DIMENSIONS WITH YOUR SALESPERSON

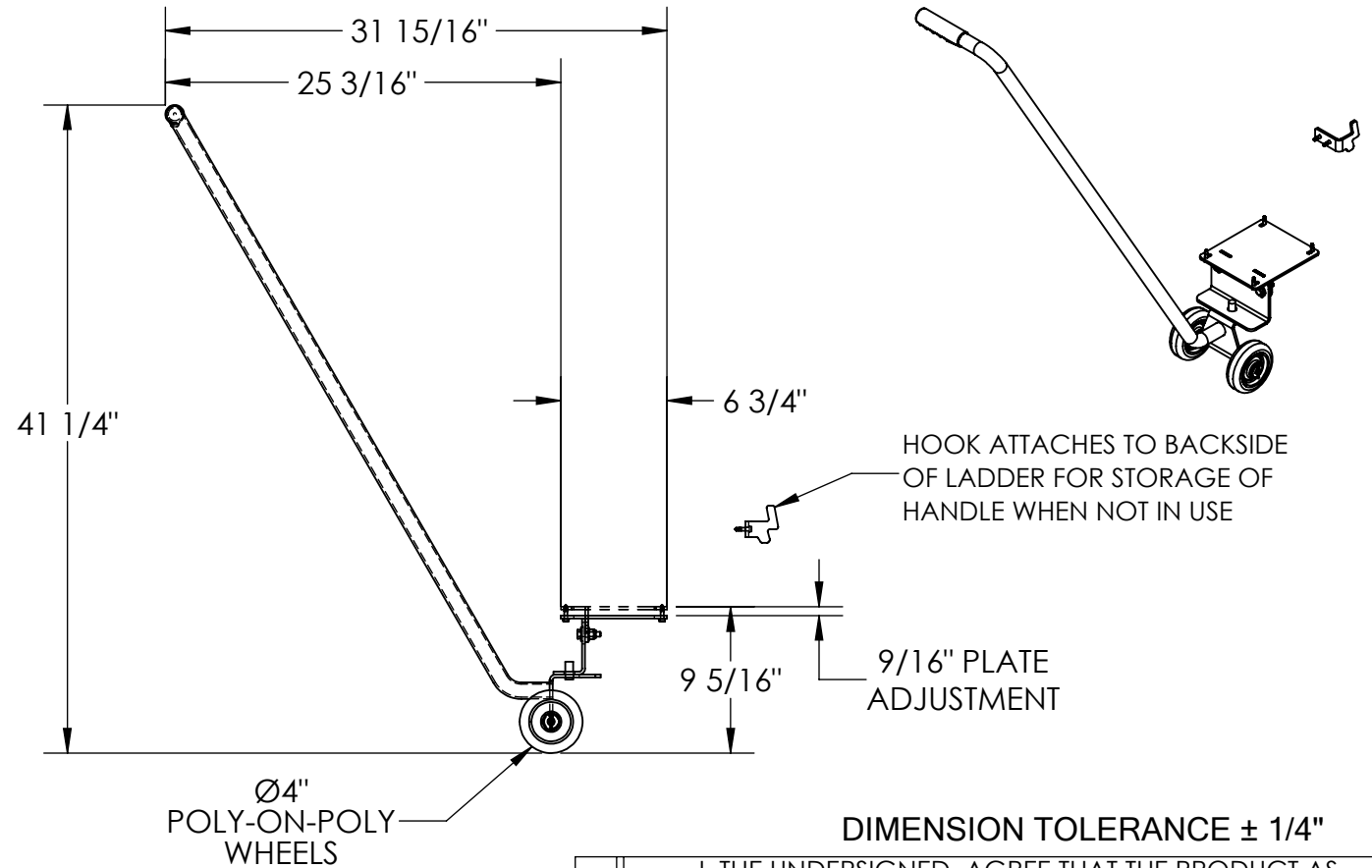
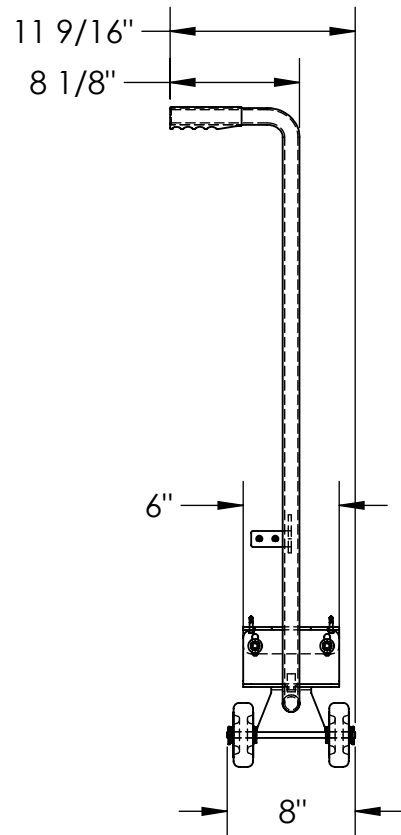

HOOK ATTACHES TO BACKSIDE OF LADDER FOR STORAGE OF HANDLE WHEN NOT IN USE

9/16" PLATE ADJUSTMENT

Ø4" POLY-ON-POLY WHEELS

DIMENSION TOLERANCE ± 1/4"

STANDARD FEATURES

MODEL NUMBER: LAD-MM-LTO
 OVERALL LENGTH: 31 15/16"
 OVERALL WIDTH: 11 9/16"
 OVERALL HEIGHT: 41 1/4"
 TOUGH BAKED IN POWDER COAT
 YELLOW FINISH

SPECIAL FEATURES

NONE

| | | |
|--|--|--|
| APPROVAL | I, THE UNDERSIGNED, AGREE THAT THE PRODUCT AS REPRESENTED SATISFIES DESIGN AND DIMENSION REQUIREMENTS. I ALSO ACKNOWLEDGE MY DUTY TO CONFIRM PRODUCT AND INSTALLATION COMPLIANCE WITH ALL APPLICABLE FEDERAL, STATE AND LOCAL REGULATIONS AND STANDARDS. | |
| | ANY MODIFIED UNITS ARE NON-RETURNABLE | |
| | [] As drawn [] As marked | |
| | Signed: _____ Date: _____ | |
| Printed Name: _____ | | |
| LEAD TIME WILL START UPON RECEIPT OF SIGNED APPROVAL DRAWING | | |

| | |
|---|--|
| FOR INTERNAL USE ONLY PROJECT SIGN OFF | |
| SALES | |
| ENG. | |
| FAB. | |
| POWER | |

| | | |
|----------------------|--|-----------------------|
| DISTRIBUTOR'S NAME: | | P.O.# |
| VESTIL MANUFACTURING | | X |
| DRAWN BY: SJG | | DATE: 5/9/2018 |
| REFERENCE: X | | SCALE: 1:12 |
| QUOTED LEAD TIME: X | | QUOTE # X |
| | | W.O.# X |
| | | SALES: X |
| | | FILE NAME: 44-007-678 |